

REVISION	DOCUM.	FIRMA	FECHA

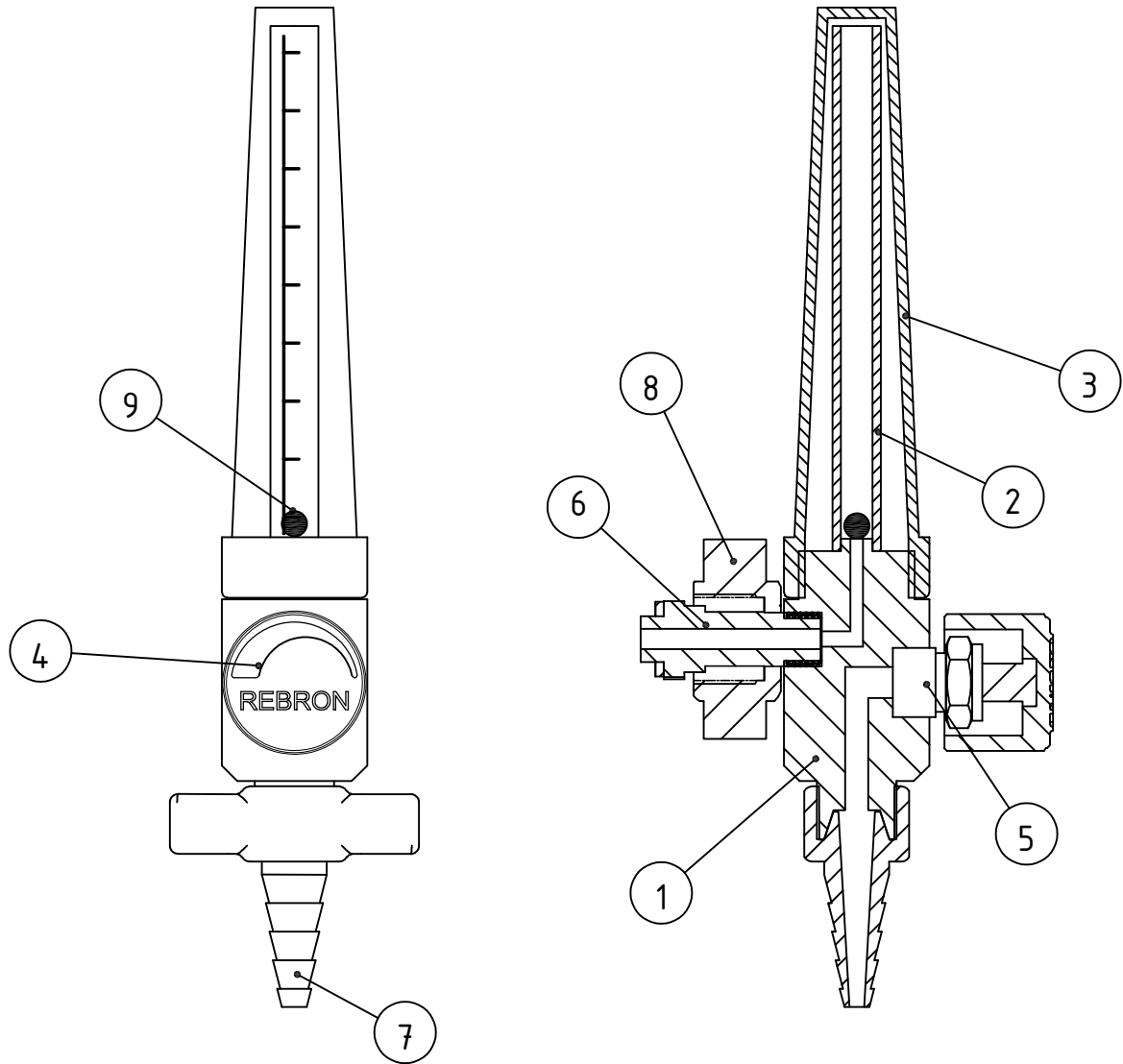
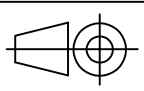

POSICION		DENOMINACION		CODIGO:		PLANO N°		CANTIDAD:	
DIBUJO: Matricerfa Govorcin		FECHA:		MATERIAL / PESO (grs)		T.TERMICO / SUPERFICIAL		DUREZA HRC	
REVISO:		FECHA:		TRATAMIENTO SUPERFICIAL: Pulido / Cuerpo cromado.		TOLERANCIA ANGULAR 0° ±1° 0°0' ±0°30'		TOLERANCIA LINEAL 0 ±0.25 0.0 ±0.1 0.00 ±0.05	
APROBO: Marcelo Garcia		FECHA:		NOMBRE DE EQUIPO O CONJUNTO/CODIGO Flowmeter cromado, para Oxígeno - 1010.		HOJA DE		ESCALA 	
				PLANO REF./ EQUIPO O CONJ. N°:		CAD - FILE:		A4	

2

1

REVISION	DOCUM.	FIRMA	FECHA

D

D

C

C

9	Bolilla de Poliamida de 1/4".	17021-4P	1
8	Tuerca Aletada con inserto 9/16 / BLANCA.	3156B	1
7	Tomagoma enterizo plástico / BLANCO.	3207	1
6	Acople Flowmeter cromado con rosca 1/8.	3004C-1/8	1
5	Porta-Volante Flowmeter cromado.	3070C	1
4	Volante para Flowmeter. / BLANCO.	1710B	1
3	Tubo externo de Flowmeter con rosca.	1708	1
2	Tubo interno con escala 15LTS.	1707	1
1	Cuerpo de Flowmeter (cromado).	3036C	1

B

B

N.º	NOMBRE	CÓDIGO	CANT.
-----	--------	--------	-------

POSICION	DENOMINACION	CODIGO:	PLANO N°	CANTIDAD:
----------	--------------	---------	----------	-----------

DIBUJO: Matricerfa Govorcin	FECHA:	MATERIAL / PESO (grs)	T.TERMICO / SUPERFICIAL	DUREZA HRC
--------------------------------	--------	-----------------------	-------------------------	---------------

REVISO:	FECHA:	TRATAMIENTO SUPERFICIAL:	TOLERANCIA ANGULAR	TOLERANCIA LINEAL
---------	--------	--------------------------	--------------------	-------------------

APROBO: Marcelo Garcia	FECHA:	Pulido / Cuerpo cromado.	0° ±1°	0 ±0.25 0.0 ±0.1 0.00 ±0.05
---------------------------	--------	--------------------------	--------	-----------------------------------

A

A

	NOMBRE DE EQUIPO O CONJUNTO/CODIGO	HOJA DE	ESCALA		A4
---	------------------------------------	---------	--------	---	----

PLANO REF./ EQUIPO O CONJ. N°:	CAD - FILE:
--------------------------------	-------------

2

1